

RECOMMENDED ROPE TERMINAL

HOISTING DIRECTION OF HANDLE FOR QUICK WINDING

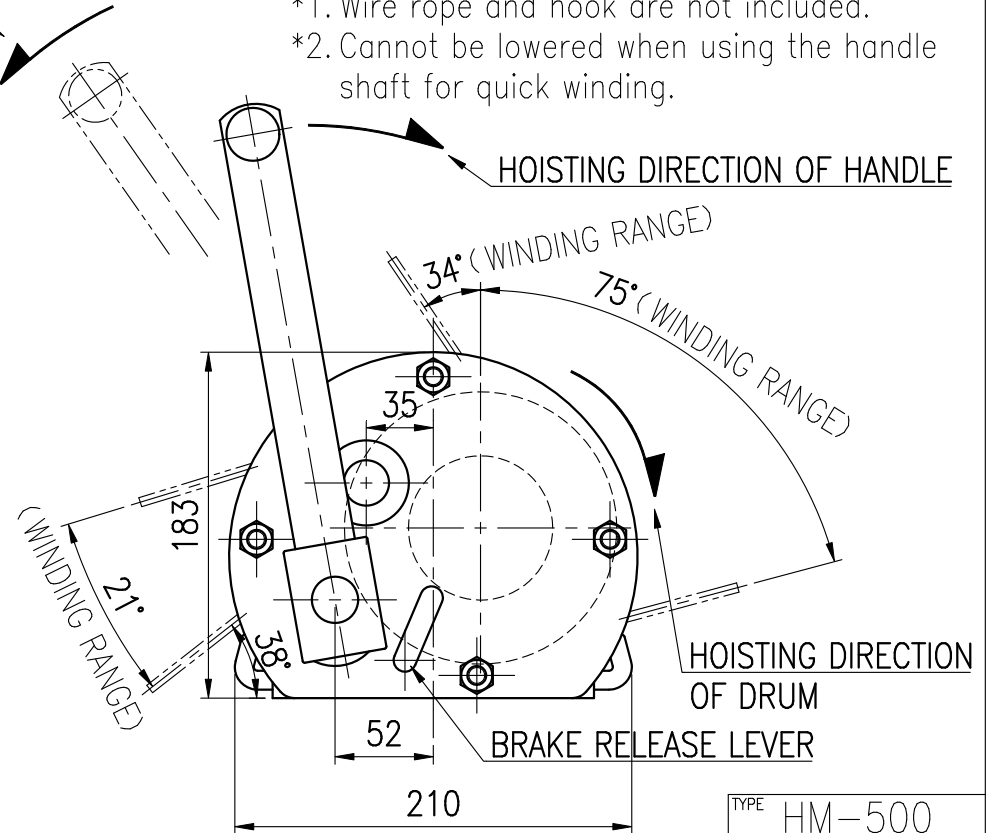
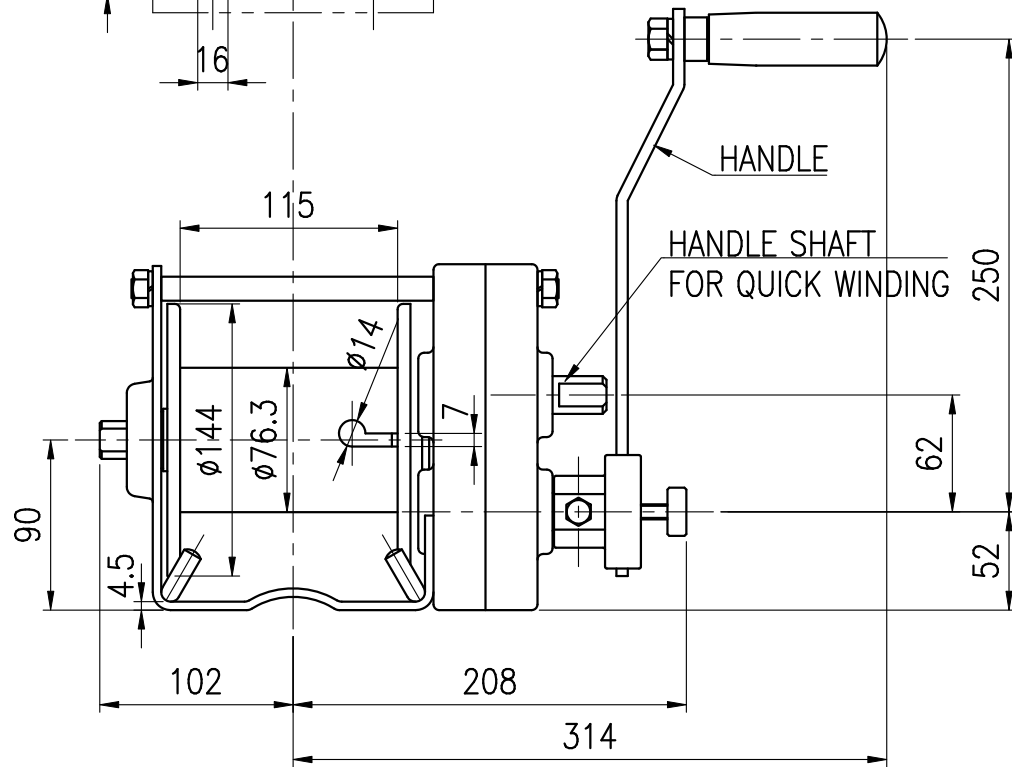

SPECIFICATION

MODEL	HM-500
RATED CAPACITY	500kg/QUICK WINDING 140kg
GEAR RATIO	12.5:1/QUICK WINDING 3.5:1
LENGTH OF WINDING	φ5×40m
HANDLE LENGTH	250 mm
HANDLE FORCE	12 kg
WEIGHT	11.2 kg (include HANDLE,HOLDER)

*1. Wire rope and hook are not included.

*2. Cannot be lowered when using the handle shaft for quick winding.

TYPE	HM-500
NAME	OUTLINE
DRAWN No.	031154