

SPECIFICATION

MODEL	BM-360H15	
POWER SUPPLY	DC 12V	
RATED LOAD	150 kg	
ROPE SPEED	10 m/min	
LENGTH OF WINDING	φ5.56×12m (aircraft cable)	
MOTOR	OUTPUT	CURRENT
	300W	35A
WINCH RATING	15min	
WEIGHT	12 kg	

Accessories 1.Wire Rope φ5.56×8m
with Swivel Hook(0.5t)
2.Handle
Safty Device Slip Clutch

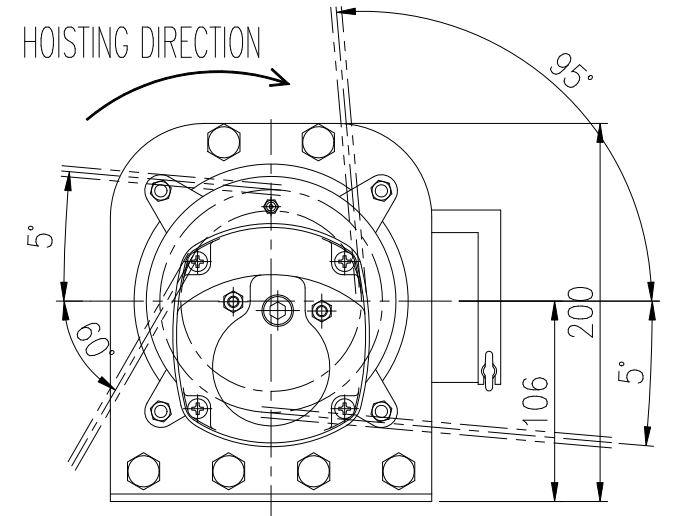
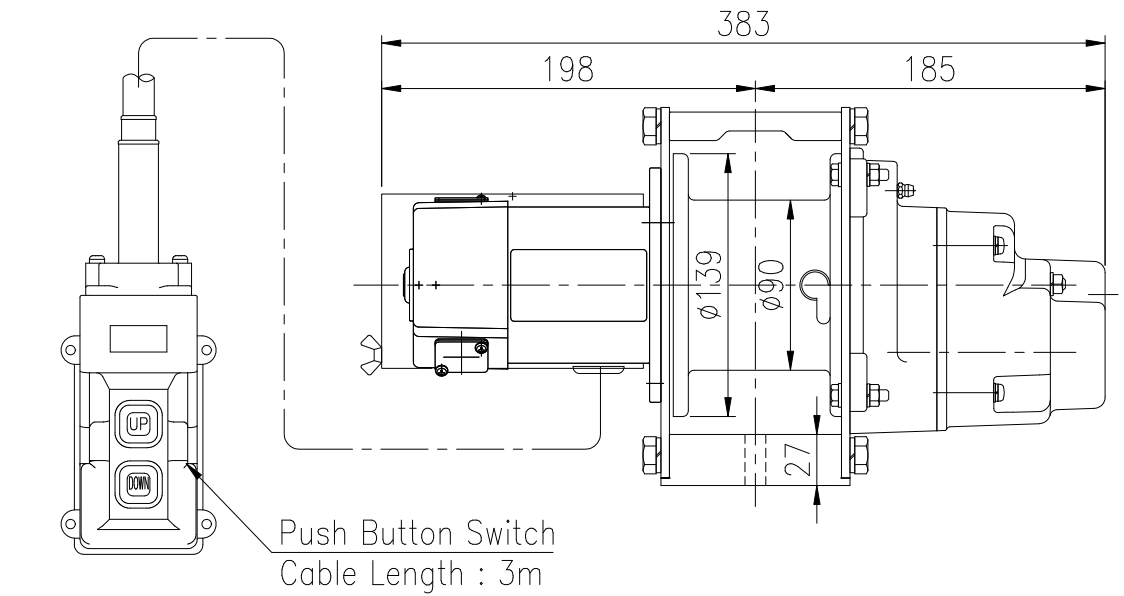

TYPE	BM-360H15
NAME	OUTLINE
DRAWN No.	029463