

SPECIFICATION

| | | |
|-------------------|----------------------------|---------|
| MODEL | BM-360H10 | |
| POWER SUPPLY | DC 12V | |
| RATED LOAD | 220 | kg |
| ROPE SPEED | 6 | m/min |
| LENGTH OF WINDING | Ø5.56×12m (aircraft cable) | |
| MOTOR | OUTPUT | CURRENT |
| | 300W | 35A |
| WINCH RATING | 15min | |
| WEIGHT | 12 kg | |

Accessories 1.Wire Rope Ø5.56×8m
with Swivel Hook(0.5t)
2.Handle
Safty Device Slip Clutch

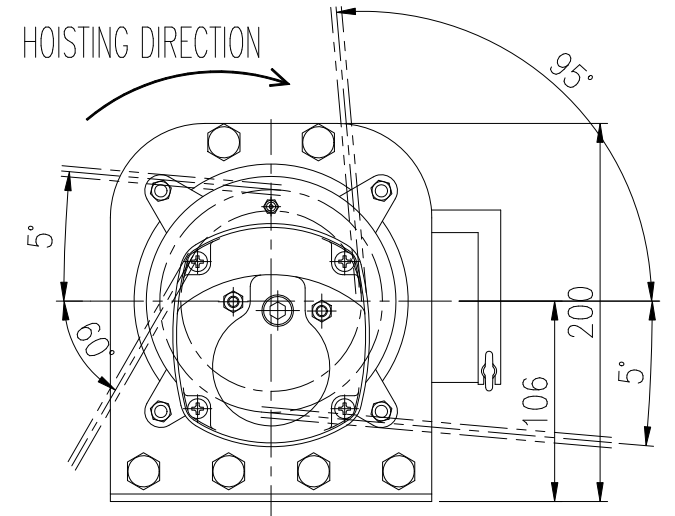
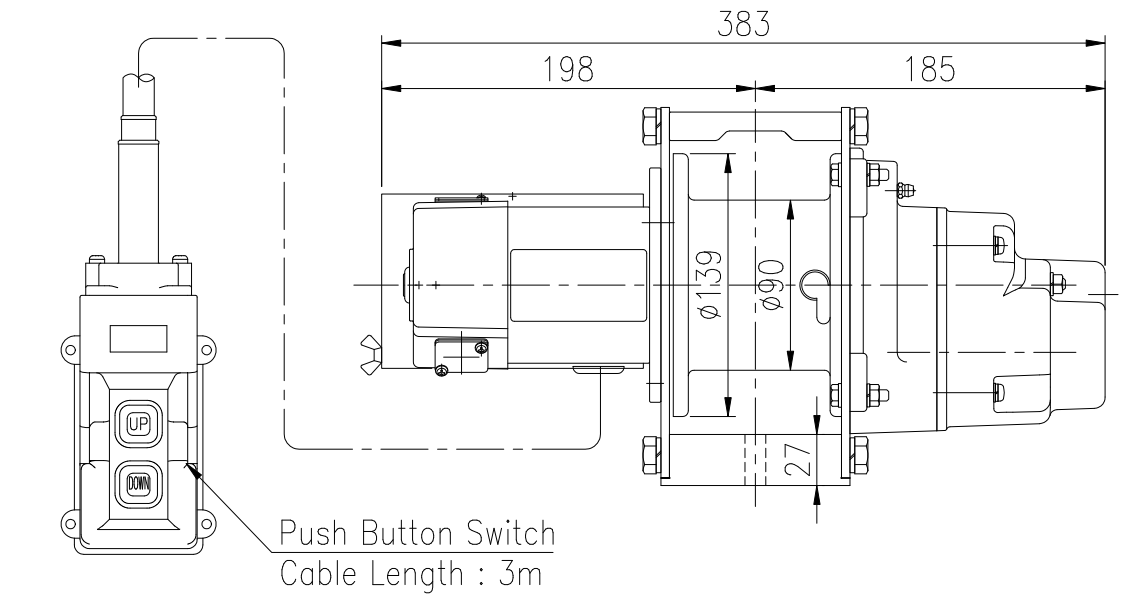

| | |
|-----------|-----------|
| TYPE | BM-360H10 |
| NAME | OUTLINE |
| DRAWN No. | 029462 |