

# SPECIFICATION

MODEL	MA-40H42		
FREQUENCY	50 Hz	60 Hz	
RATED LOAD	3000 kg	3000 kg	
ROPE SPEED	43 m/min	52 m/min	
LENGTH OF WINDING	φ18×250m, φ18×110m×2		
MOTOR	OUTPUT	POLES	VOLTAGE
	28kW	8P	200V
ISO CLASS	M5		
WEIGHT	1630 kg		

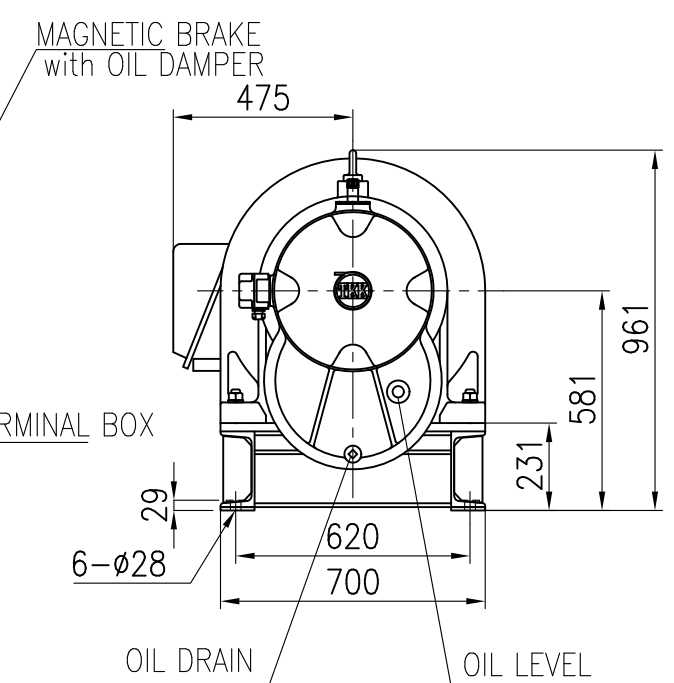
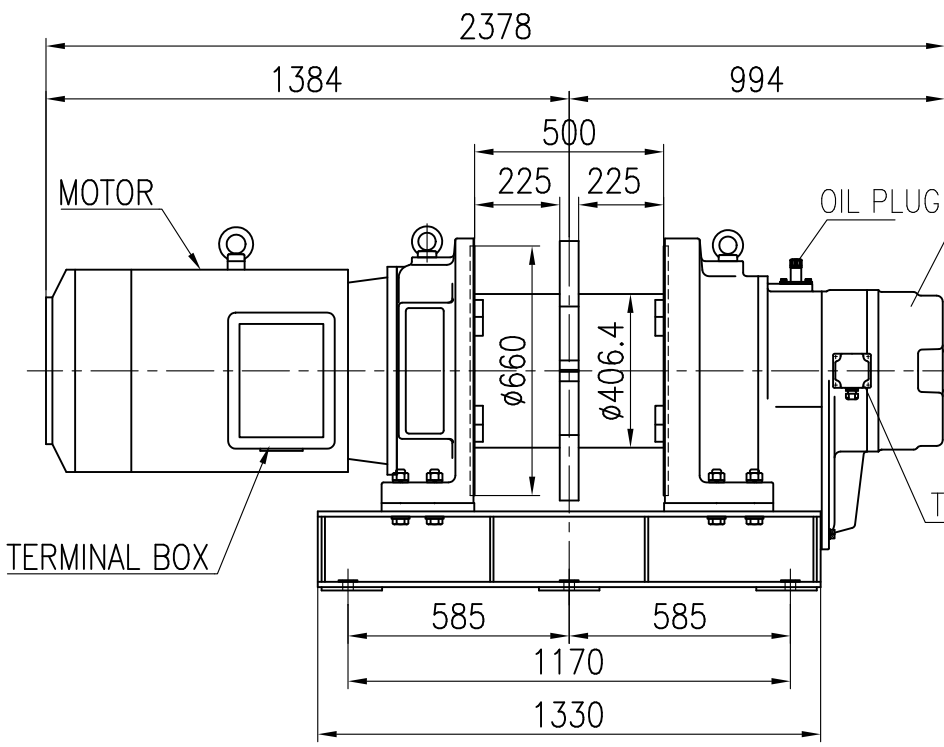
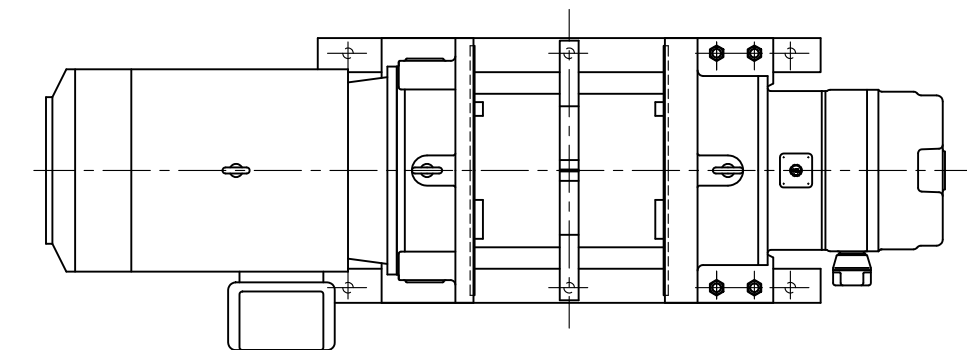

TYPE	MA-40H42
NAME	OUTLINE
DRAWN No.	052960 △